





*Quality products, good communication,
flexibility and excellent service,
Commonfield provide all of the above.*

-Jarvis Homes Ltd

ABOUT US



As a leading British manufacturer of fitted furniture solutions, Commonfield® have a new bathroom collection to add to our current product range.

We have been designing, manufacturing and installing kitchens, bedrooms and bathrooms for over **25 years** and have built a reputation for **quality products** and service which is recognised with our industry accreditations.

While first class quality goes without saying, the breadth of choice in our range of bathroom units, accessories and materials means our designers have at their finger tips all the elements they need to create the bespoke bathroom solutions your project – and ultimately your homebuyer – demands.

WHY CHOOSE US

- Competitive manufacturer's prices
- High quality products
- Fully accredited
- Innovative design team to suit every brief
- In house manufacturing
- Highly skilled installation team



MIRROR CABINETS

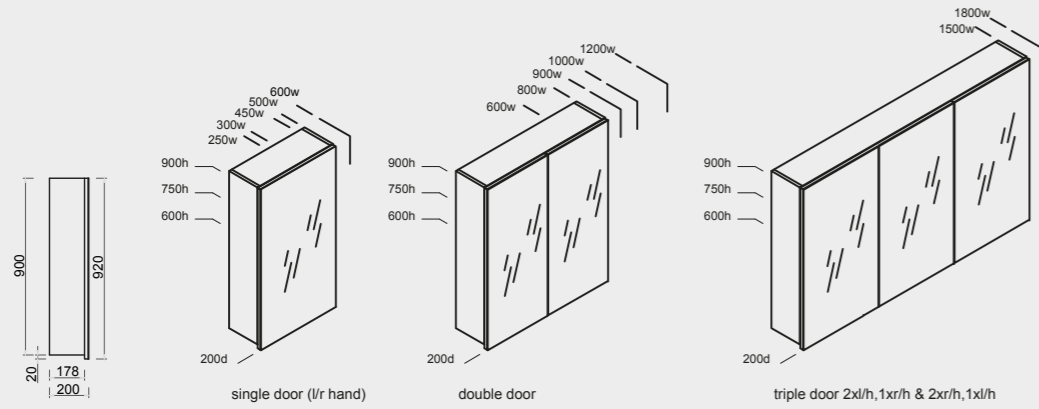

VANITY DRAWER UNITS

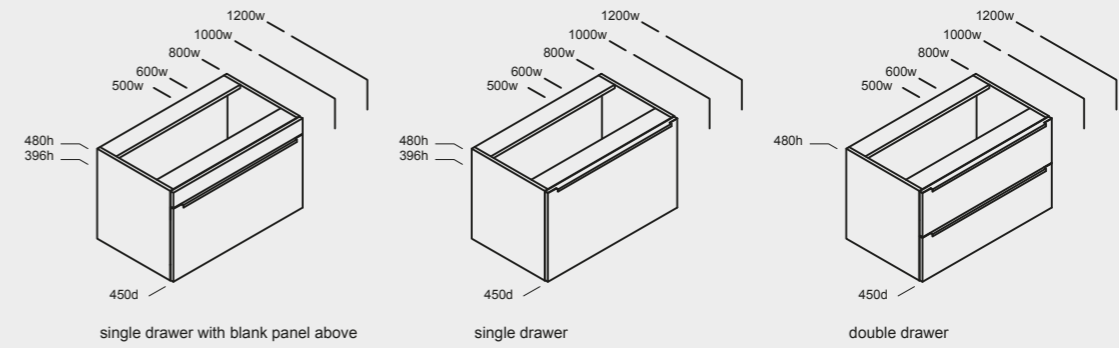

SLIDING DOOR CABINETS

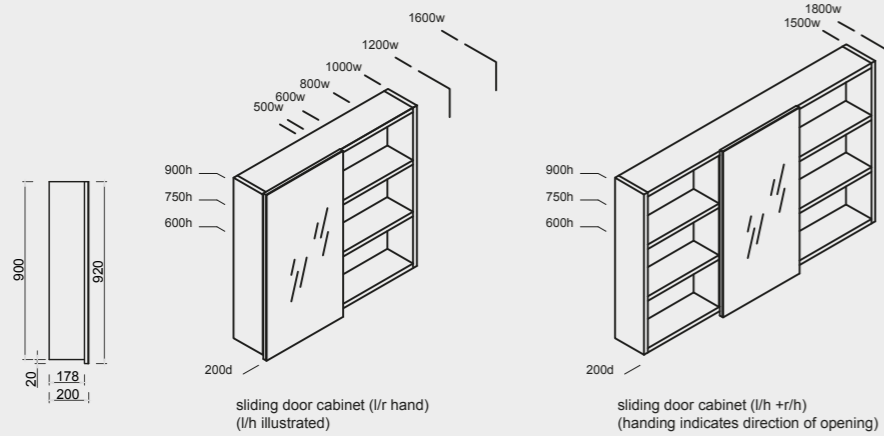

VANITY DOOR UNITS

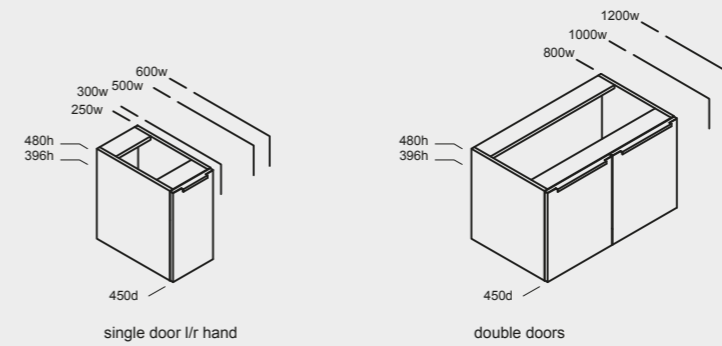

OPEN SHELF UNITS

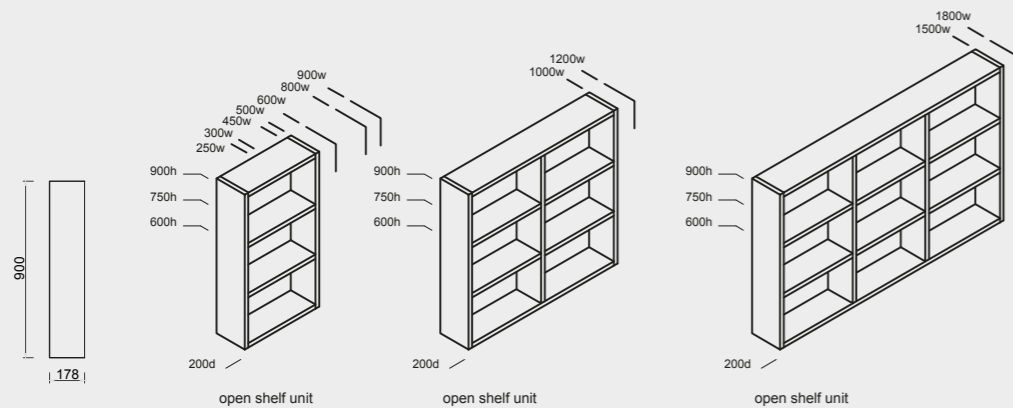

WORKTOPS

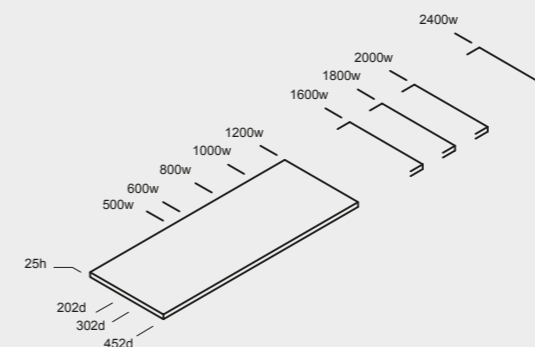

FRAMED MIRRORS 600w

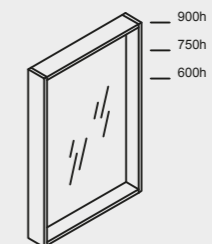

FREESTANDING UNITS

countertop height

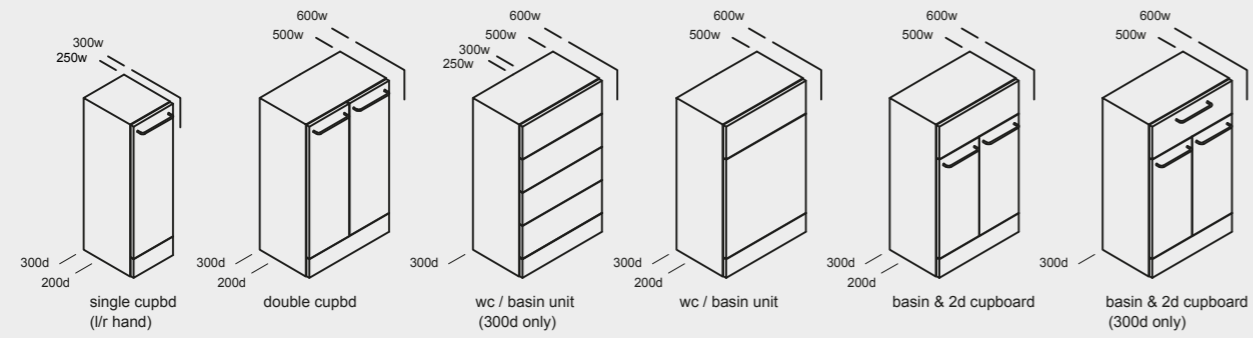

FREESTANDING UNITS

full height shelves & cupboards

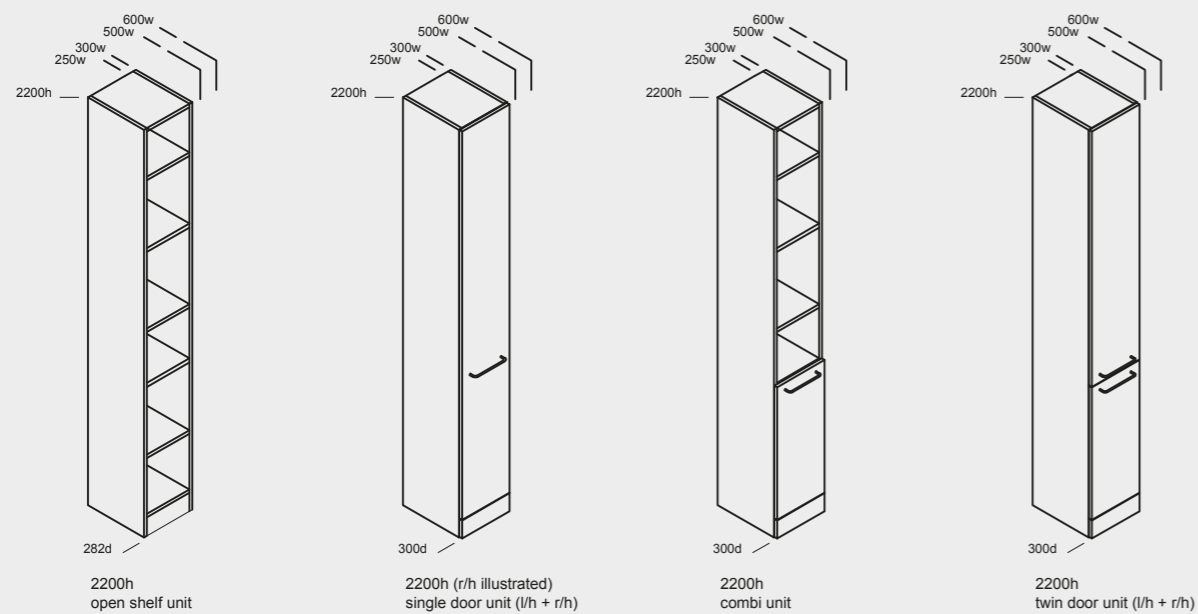

GLASS OPTIONS



SILVER MIRROR
MG304 (band 1)

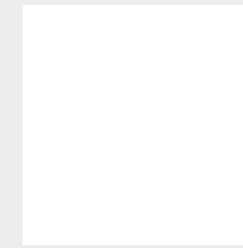

PURE WHITE
LL118 (band 2)

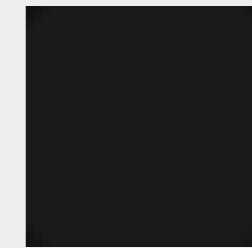

BLACK CLASSIC
LL116 (band 2)

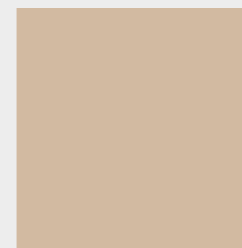

STONE GREY
LL502 (band 3)

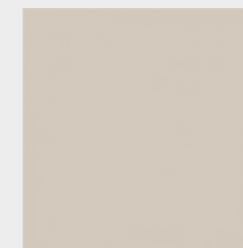

CASHMERE
LL500 (band 3)

INDEPENDENT PANEL SYSTEM

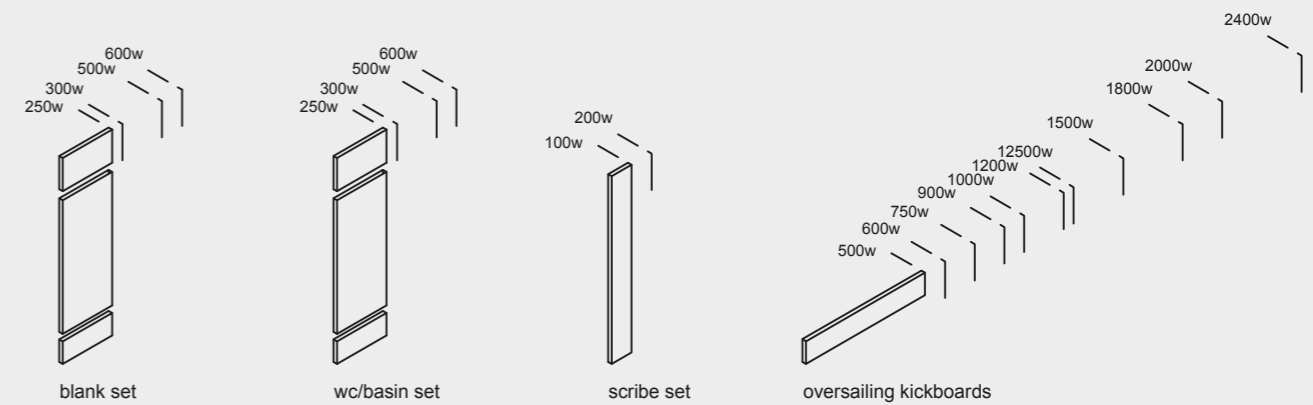

FLOATING WALL UNITS

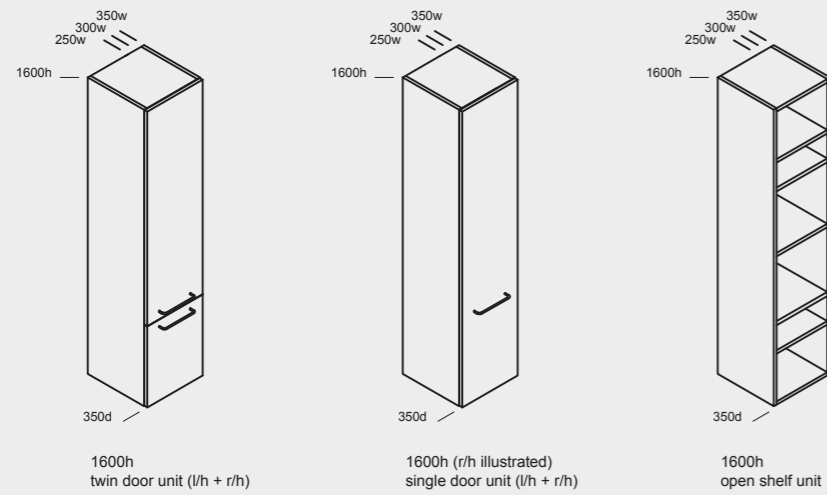

MODULAR GLASS SPLASHBACKS

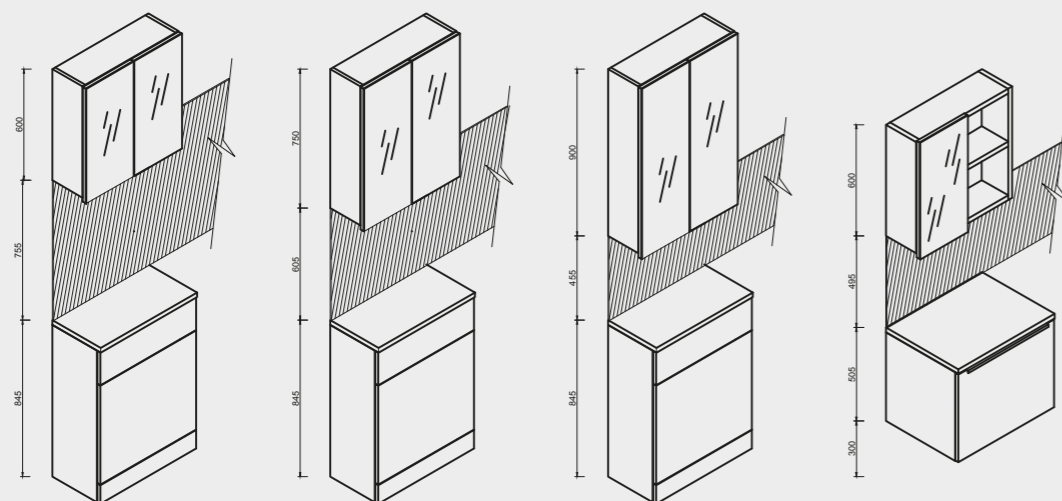

MOISTURE RESISTANT BOARD OPTIONS

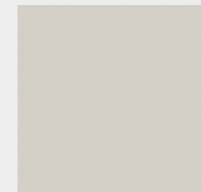

LIGHT GREY
U708 ST9 (Band 1)

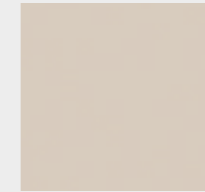

CASHMERE GREY
U702 ST9 (Band 1)



STONE GREY
U727 ST9 (Band 1)



DUST GREY
U732 ST9 (Band 1)

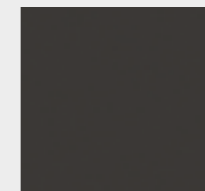

SOFT BLACK
U899 ST9 (Band 1)

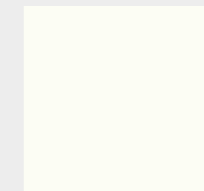

ALPINE WHITE
W1100 ST9 (Band 1)

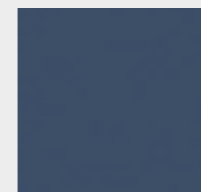

TYROLEAN BLUE
U504 ST9 (Band 2)



CURRY YELLOW
U163 ST9 (Band 2)



SIENA ORANGE
U350 ST9 (Band 2)



LIGHT GREY CHICAGO CONCRETE
F186 ST9 (Band 2)

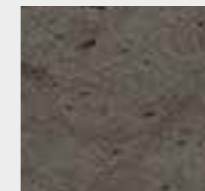

DARK GREY CHICAGO CONCRETE
F187 ST9 (Band 2)

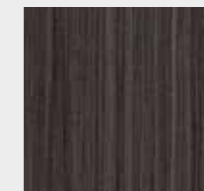

ANTHRACITE FINELINE METALLIC
H3190 ST37 (Band 2)



NATURAL HALIFAX OAK
H1180 ST37 (Band 3)

ACCESSORIES

A range of surface mounted and inset handles are available to compliment our product range. Built-in demister pads are a great feature to safely and gently heat up your mirror and quickly clear the steam.

Under cabinet LED lighting is also available and another great feature to elevate your finished bathroom look.

CARE AND MAINTENANCE

Our mirrors are **moisture edge protected** during manufacture. To avoid black spotting appearing on mirrors over time make sure your bathroom is well ventilated and ammonia based cleaning products should be avoided to prevent edge deterioration.





MANUFACTURED IN THE UK

Complete control of our manufacturing means we have complete capability and a degree of agility that's hard to beat. It gives us a rare flexibility in product specification, which means we are rarely beaten on price.

What's more we can meet your deadlines with the shortest lead times thanks to our 40,000 sq.ft Dunstable factory equipped with the latest CNC & edge banding technology.

FULLY ACCREDITED

At Commonfield® we are very proud of our industry accreditations in Quality Management (ISO 9001), in our drive for sustainability and environmental responsibility (ISO 14001 & FSC), in Health & Safety (through ISO 45001, SMAS & CQMS) and in fleet management (FORS).

That quantity capability is underpinned by a commitment to quality embodied in ISO 9001, ISO 45001, SMAS and CQMS accreditations and a deeply embodied Health & Safety and environmentally conscious culture

Please ask about our FSC certified products.



COMMONFIELD®

Commonfield Services Ltd
Units 1,2,3 7a & 8
Lawrence Way Industrial Estate
Brewers Hill Road
Dunstable | LU6 1BD

t: +44 (0) 1582 697750
e: sales@commonfield.com
w: commonfield.com

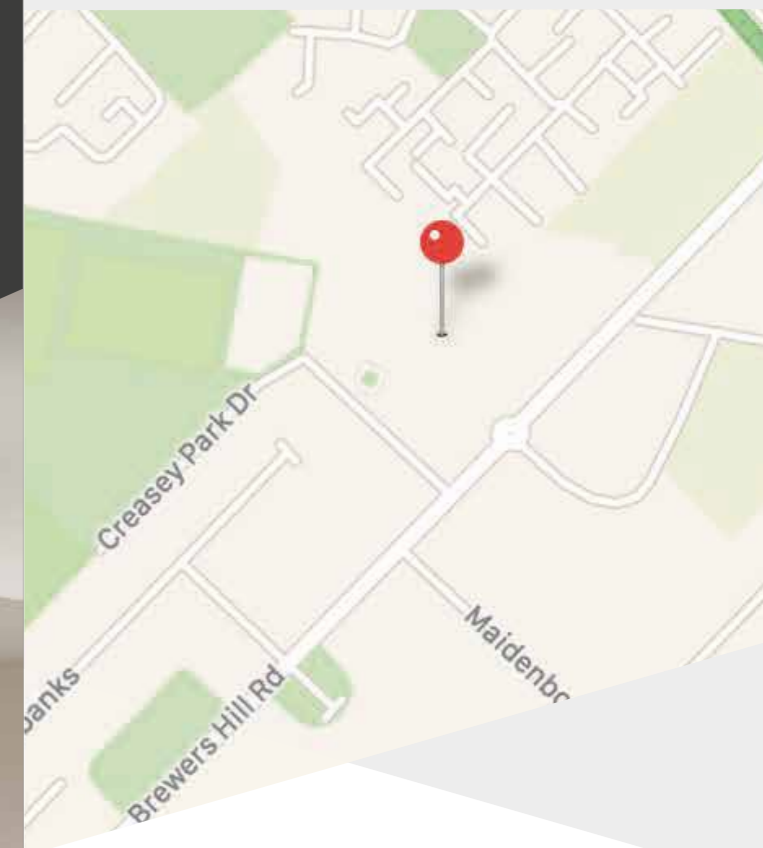

After 25 years in business, Commonfield understands the benefit of teamwork, training, tolerance & respect for people and our environment.



